

Rockwell service letter

No. SL-AG-33

International

P.O. BOX 3090 ALBANY, GEORGIA 31706-3090 PHONE 229/883-1440 FAX 229/439-9790

Service Letter No. SL-AG-33
March 20, 1964

HORIZONTAL STABILIZER LEADING EDGE VIBRATION

APPLICABILITY: S-2B & S-2C models,
Serial No. 1038B & SUBS
1080C THRU 1206C

During overhaul of several horizontal stabilizers in the plant, there have been noticed cracks in the weld connections of the first several inboard ribs to the main spar. The probable cause of this cracking is vibration of the leading edge of the horizontal stabilizer due to slipstream effects of the larger engines. It is recommended that all operators of Snow S-2B and S-2C airplanes perform the following inspection and take corrective action as necessary. It should be noted that this situation is most likely to develop in 600HP S-2C airplanes which had the extended horizontal stabilizer (Serial # 1149C and Subs.).

The following action should be taken:

1. Provide inspection holes in the fabric on the lower side of the horizontal stabilizer. The inspection cover rings should be installed directly over the front spar and midway between the 1st and 2nd ribs and 3rd and 4th ribs on both sides (starting from center of airplane).
2. Check the weld between spar and ribs carefully (use flashlight and mirror).
 - a. If no cracks are found it is recommended that Service Kit #33 be installed.
 - b. If minor cracks are found, repair according to Civil Aeronautics Manual 18 procedures and install Kit #33.
 - c. If severe cracking is present, contact the factory for availability of heavier and stress relieved stabilizer.
3. Service Kit #33 consists of two clamps-on braces which extend from the stabilizer leading edge of lower fuselage cluster just forward of it (see sketch). This service kit is FAA approved.

INSTALLATION INSTRUCTIONS:

- a. Remove skins on aft fuselage.
- b. Cut fabric around leading edge at two locations as shown in sketch,
- c. Attach clamps 50 5/8" x .035" leading edge tube of stabilizer.
- d. Attach Dutchman clamps at 3/4" x .035" fuselage tube near bottom cluster (see sketch).
- e. Fasten braces to clamps.
- f. Tighten braces (light tension desirable).
- g. Patch cuts in fabric around clamps at stabilizer leading edge tube.
- h. Re-fasten skin panels.

(h) Re-fasten skin panels.

LEADING EDGE TUBE OF STABILIZER

SERVICE KIT #33
REVISED PARTS LIST

ITEM	PART NO	NO. REQ	DESCRIPTION
1	5-4033-1	2	BRACE
2	5-4033-5	X 4	DUTCHMAN CLAMP
3	AN3-20	2	CLAMP
4	AN3-4A	4	BOLT
5	AN365-1032	X 12	NUT
6	AN960-10	X 12	WASHER
7	AN3-12A	X B	BOLT
8		4	INSPECTION RING
9		4	INSPECTION PLATE
10	5-4033-6	4	HALF TUBE

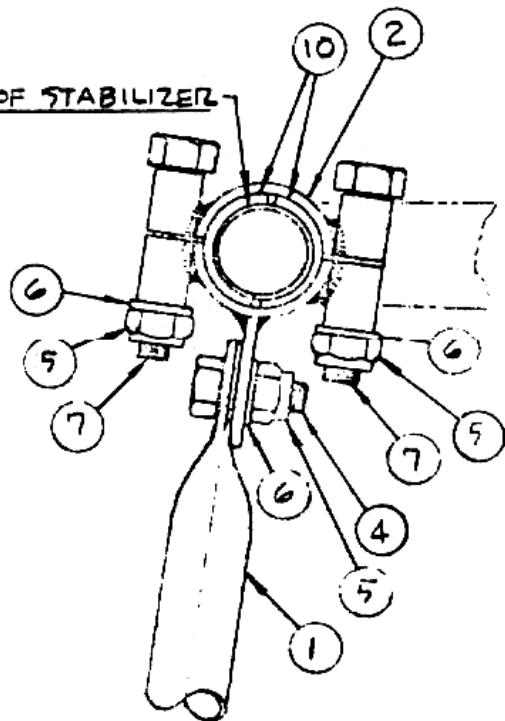

REVISED ATTACHMENT
TO LEADING EDGE TUBE