

SERVICE BULLETIN

SB-AG-65

Revision IR 11/20/2017

**Installation of Click Bond Electrical
Grounding Spacer Stud on the Header Tank**



James Alman

Vice President of Engineering

AIRCRAFT AFFECTED:	
<u>MODEL</u>	<u>SERIAL NUMBERS</u>
S2R-H80	101 through 200

LOG OF REVISIONS

NOTE: Re-formatting and correction of typographical errors is not considered revision. True revisions are indicated by a dark vertical line at the right margin of the lines revised.

Rev.	Page	Description of Revision	By:
IR	All	New Document Initial Release to provide modification instructions, material, and hardware required to install the Electrical Grounding Spacer Stud.	Levan Tabidze 10/01/2017

Contents

LOG OF REVISIONS	ii
1. PURPOSE AND REASON FOR PUBLICATION.....	1
2. SCOPE/COMPLIANCE.....	1
3. BY WHOM WORK WILL BE ACCOMPLISHED	1
4. APPROVAL	1
4.1 THRUSH AIRCRAFT, INC. APPROVAL	1
4.2 FAA ACCEPTANCE	1
5. MAN HOURS.....	1
6. NEW PARTS AND MATERIAL	1
7. MODIFICATION INSTRUCTIONS	2
8. RECORD OF COMPLIANCE.....	6
9. SERVICE BULLETIN SB-AG-65 REV. A COMPLIANCE REPORT	7

1. PURPOSE AND REASON FOR PUBLICATION

Thrush Aircraft, Inc. was notified about reduced service life of the Weldon continuous duty fuel pumps. Investigation revealed that installation of these pumps does not provide consistent electrical bonding to the airframe. This Service Bulletin provides installation instructions for the Electrical Grounding Stud and the associated electrical bonding strap. This modification provides a consistent ground.

2. SCOPE/COMPLIANCE

Compliance with the Service Bulletin is required to secure warranty of short service life continuous duty Weldon fuel pumps.

3. BY WHOM WORK WILL BE ACCOMPLISHED

This work is to be accomplished by a FAA Certified A & P mechanic or equivalent.

4. APPROVAL

4.1 THRUSH AIRCRAFT, INC. APPROVAL

This Service Bulletin is approved by the Vice President of Engineering at Thrush Aircraft, Inc.

4.2 FAA ACCEPTANCE

Required acceptance.

5. MAN HOURS

1 Man Hour

3 Hours elapsed

6. NEW PARTS AND MATERIAL.

Part Number	Designator	Quantity	Special Information
CB9567 CRM 420-10-20	¼ X 20 UNC-2A	1	Electrical Grounding Spacer Stud
CB200 Acrylic Adhesive	CB200	1	Acrylic Adhesive
¼" X 20 UNC		1	Nut
AN960C416	¼"	2	Flat Washer
¼"		1	Lock Washer
90176T270		1	Ground Strap Assembly
White Touch Up Paint		As Required	Operator Supplied
FR Primer		As Required	Operator Supplied
Alodine		As Required	Operator Supplied

7. MODIFICATION INSTRUCTIONS

- 7.1 Place the aircraft in a suitable maintenance facility. Recommended to Defuel Airplane.
- 7.2 Remove those aircraft skins and fairings necessary to gain access to the header tank on the aircraft right-hand side, located under the cockpit. See Figure 65-1.

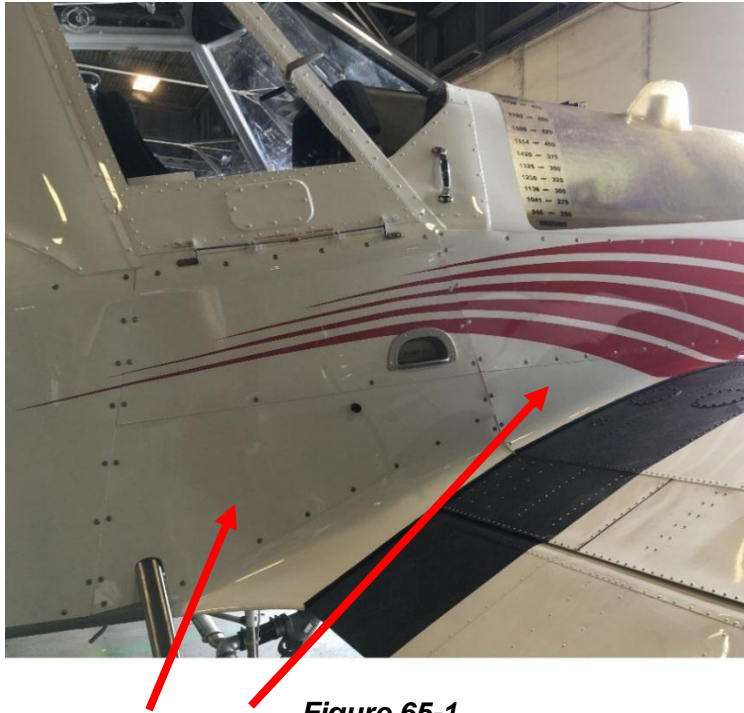

Figure 65-1

- 7.3 Using Scotch-Brite™ (or similar nonmetal) pads remove paint, and primer on the header tank top surface. Make sure not to remove any metal. Removed area shall be, approximately 2.25 inches by 1.125 inches for installing the Click Bond Electrical Grounding spacer stud. Remove all foreign material and clean thoroughly reworked area as well as area around it.
- 7.4 Figure 65-2 is the location of the reworked area.



View from the right side

Figure 65-2

7.5 Figure 65-3 shows the ground stud configuration prior to installation.

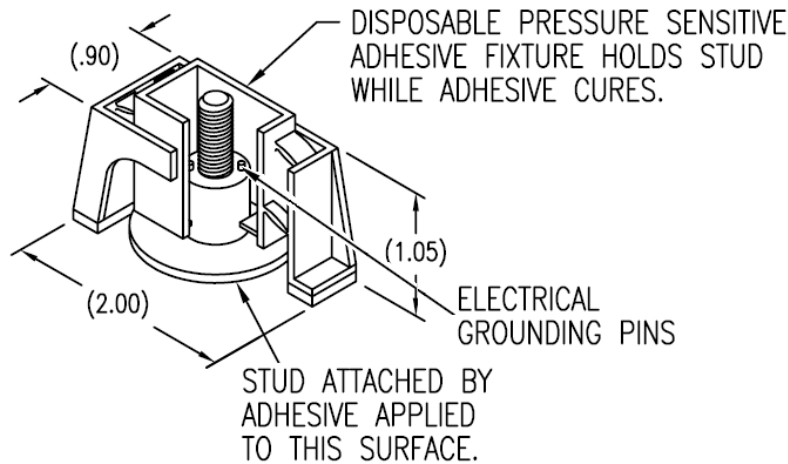

Figure 65-3

7.6 Read the CB200 Acrylic adhesive mixing instructions located on the package prior to starting step 7.7.

7.7 Install the Click Bond Electrical Grounding spacer stud per the instructions and figures shown below.

7.7.1 Solvent wipe the fastener base and the prepared area on the header tank.

7.7.2 Remove the peel ply from foam tape pads and discard.

7.7.3 Apply the mixed adhesive to the fastener baseplate. Do not overapply. The amount needs to be enough to cover the entire area to properly bond. A film a few thousandths thick is adequate.

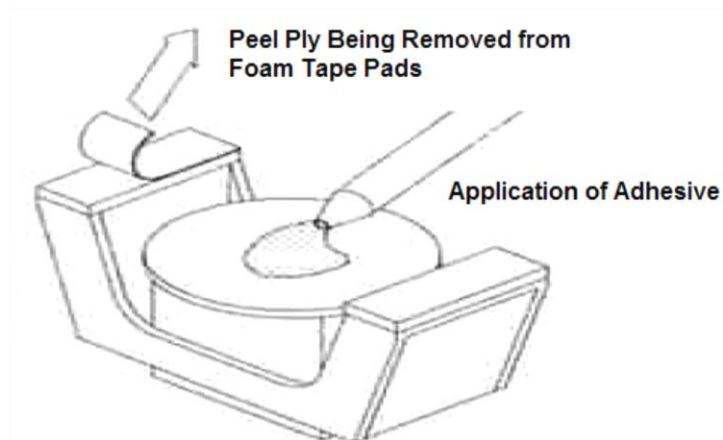

Figure 65-4

7.7.4 Locate the ground stud assembly over the area where paint, primer, and corrosion protection layer was removed.

7.7.5 Press down on the outer body to adhere the foam tape to the surface.

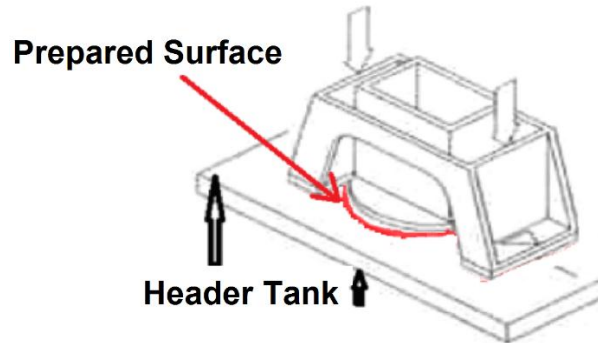

Figure 65-5

- 7.7.6** Press down on the inner body of the ground stud assembly to actuate. The application of force should cause a “click” as the plastic install device locates the stud.
- 7.7.7** Do not press on the protruding fastener.
- 7.7.8** Verify all exposed edges of bonded stud show a continuous adhesive bead squeezing out along the joined surfaces.
- 7.7.9** Allow the adhesive to cure for 2 hours at 75° F.
- 7.7.10** Using pliers, pull the outer fixture from the substrate.

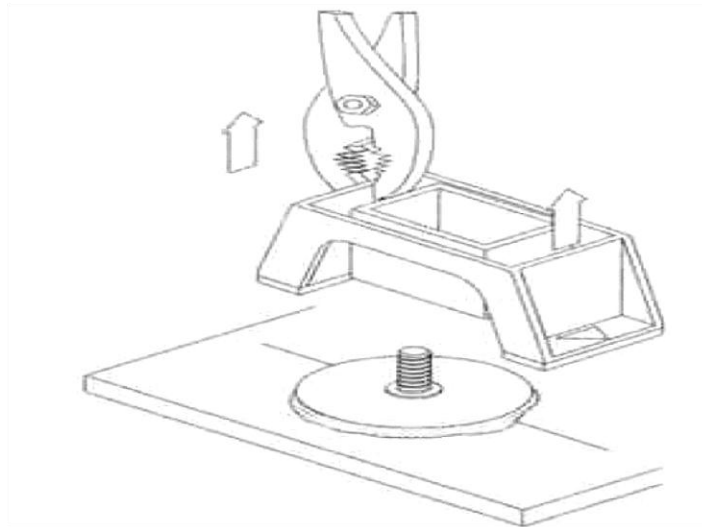

Figure 65-6

- 7.7.11** Verify that the stud is firmly attached by applying 5 lbs. of force to the threaded portion. Discard fixture.
- 7.7.12** Install 90176T270 ground bonding strap in this order: flat washer, terminal lug from ground strap assembly to stud, flat washer, lock washer and the nut.

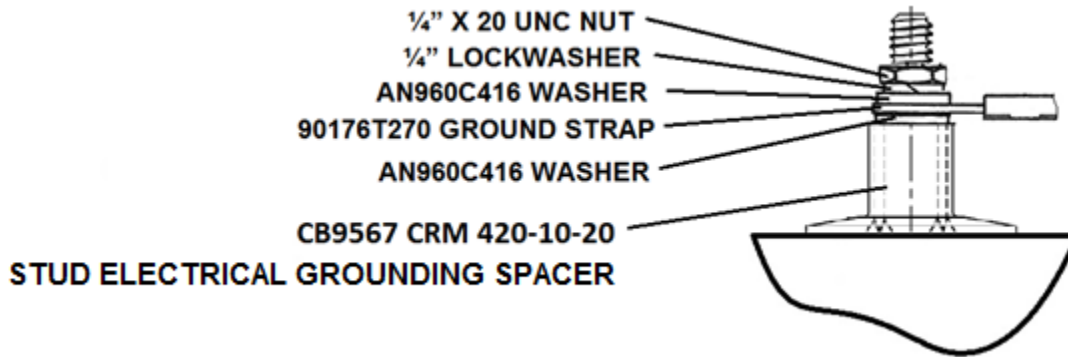

Figure 65-7

- 7.7.13** Tighten nut until ground pins of the strap penetrate adhesive. Do not overtighten as over-torque could damage the installation.
- 7.7.14** After removing paint from the Flap Shaft Bolt seat, attach other end of the Ground Strap Assembly to Flap Shaft Bolt and secure with existing hardware. The Ground Strap Assembly Terminal can replace the existing washer under the head of the Flap Shaft Bolt.
- 7.7.15** Use an ohm meter to verify a good ground. Measuring from the tank surface to the negative battery lead, Ohm meter should not show any resistance. The aft pin of the ground power plug is also a good alternate ground location.

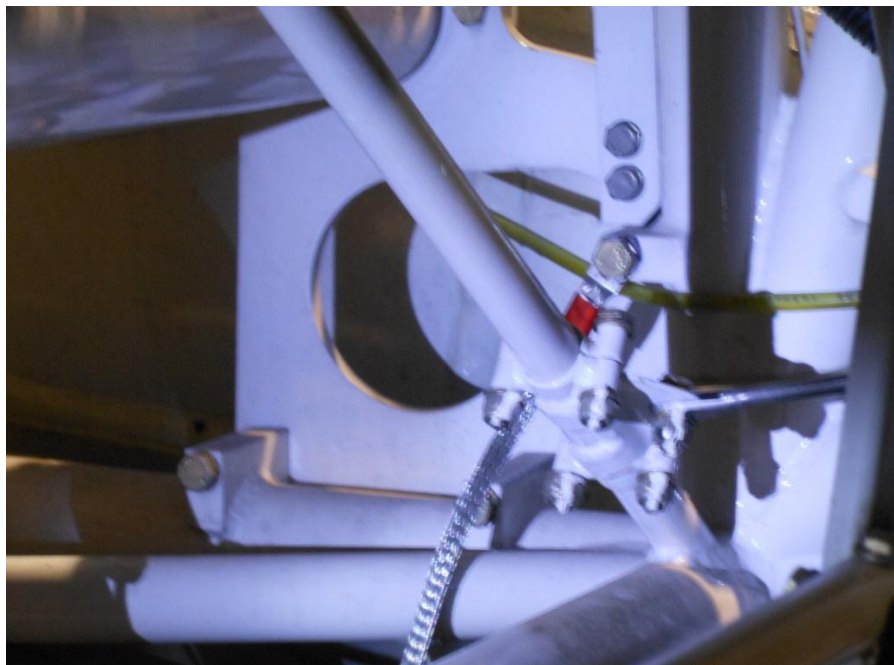

Figure 65-8

- 7.7.16** Alodine and apply primer and paint to all exposed metal left by the spot face. Applications shall be conducted per manufacturer's instructions.

8. RECORD OF COMPLIANCE

Make the following appropriate entry in aircraft log book.

**“Thrush Service Bulletin SB-AG-65 Rev. A complied with at _____
total hours on aircraft.”**

(Name & Certificate #)

(Signature)

(Date)

Complete and return the Compliance Report on the next page.

9. SERVICE BULLETIN SB-AG-65 REV. A COMPLIANCE REPORT

Aircraft S/N: _____ Aircraft Owner: _____

Aircraft Registration # _____ Address of Owner: _____

Airframe total time: _____ City & State: _____

Engine total time: _____ Physical location: _____

Date of Compliance _____

Complied with by: _____ Certificate #: _____

Signature: _____

RETURN THIS REPORT ONLY AFTER REPAIR/MODIFICATION IS COMPLETE.

Mail response card, or fax this card to (229) 439-9790, or e-mail to erusk@thrushaircraft.com.

Fold, Tape & Mail (Do Not Staple) **Don't forget postage**

Return Address

THRUSH AIRCRAFT INC.

Attn: Ed Rusk
300 Old Pretoria Road
Albany, GA 31721