

Rockwell service letter

No. SL-AG-28

International

P.O. BOX 3090 ALBANY, GEORGIA 31706-3090 PHONE 229/883-1440 FAX 229/439-9790

Service Letter No. SL-AG-28
September 12, 1963

TAILWHEEL TRUNNION ATTACH SHAFT

APPLICABILITY: All S-2A Aircraft, Serial Number 1003 thru 1189

There have been reports of failures of the tailwheel trunnion attach shaft. A solid stainless shaft (P/N 5-5008-16) is available to replace the existing shaft.

This service letter is in two parts:

- A. for airplanes which have a $\frac{1}{2}$ " O.D. trunnion attach shaft.
 - B. for airplanes which have a $\frac{3}{4}$ " O.D. trunnion attach shaft.
- A. The following steps should be performed to install the new shaft on airplanes with an existing $1\frac{1}{2}$ " O.D. trunnion attach shaft.
1. With the tail of the airplane supported, remove the tailwheel trunnion from the airplane.
 2. Drill one #3 (.213) diameter hole in the area of the forward gusset on each side of the trunnion. These holes should be located at the center of each bronze bearing laterally and when viewed from the sides the centerlines of the holes should point down and forward at about 15 degrees to the bottom of fuselage when the trunnion is in place. The holes should be drilled through the gusset, the trunnion forward lateral tube, and the bronze bearing. Three each holes with a $\frac{1}{4}$ x 28 tap. Remove the zerk fittings from the old trunnion attach shaft and install them in these holes.
 3. Replace the trunnion on the airplane, installing the new solid trunnion attach shaft. Grease the bearings through the newly installed zerk fittings.
- B. The following steps should be performed to install the new shaft on airplanes with an existing $\frac{3}{4}$ " O.D. trunnion attach shaft.

1. With the tail of the airplane supported, remove the tailwheel trunnion from the airplane.
2. Insert one of the reamed steel bushings in each end of the 7/8 x .058 trunnion forward lateral tube such that the end of the bushing is flush with the end of the tube. Weld around the edges to fasten the bushing to the tube.
3. Press one bunting bronze bearing into each steel bushing which was welded into the trunnion in step 2 above.
4. Perform step 2 from instruction A above.
5. Insert one of the reamed steel bushings in each trunnion attach bracket on the fuselage frame. Weld around the edges of the outside to fasten the bushing to the tube of the fuselage bracket.

NOTE: On some airplanes, it will be necessary to cut 1/4" off two of the steel bushings which come with this kit to make them fit the tube lengths of the fuselage trunnion attach bracket. This also applies to two of the bunting bronze bearings which are pressed into this bushing on the next step.

6. Press one bunting bronze bearing into each steel bushing which was welded to the fuselage trunnion bracket in step 5 above.
7. Replace the trunnion on the airplane installing the new solid attach shaft. Grease the bearing through the newly installed zerker fittings.

Be sure to give the outside diameter of the trunnion attach shaft on your airplane when ordering this service kit.

Parts List for "A" above; 1/2" O.D. shaft

Trunnion attach shaft (P/N 5-5008-16)	1 required
---------------------------------------	------------

Parts List for "B" above; 3/4" O.D. shaft

1. 3/4 x .065 x 1 1/2 long 4130N steel tube reamed to .625±.001 diameter 4 required
2. bunting bronze bearing, bunting P/N P50-12, 5/8 O.D. x 1

ENGINEERING ORDER

NO. 5-5008 E

SNOW AERONAUTICAL CORPORATION

OLNEY, TEXAS

BY BARNHOUSE

DATE 9-11-63

MODEL 5-2C

REF DWG 5-5008

S/N 1190C AND SUB

PAGE 1 OF 1

- (1) ADD A TRUNNION ATTACH SHAFT, P/N 5-5008-16 TO THE F/D AND B/M. MATL OF SHAFT IS 1/2" DIA ROD OF 303 STAINLESS STEEL, 1/4 HD.

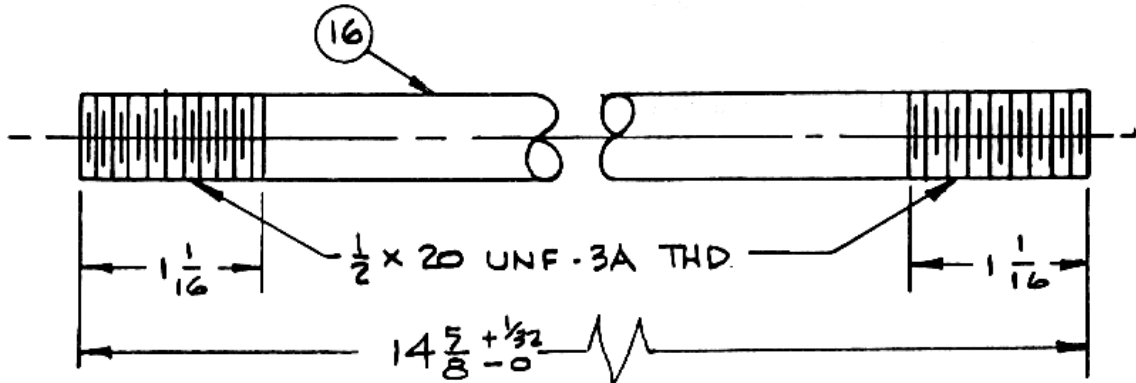

- (2) DELETE P/N 5-5008-9.

- (3) IN THE SIDE AND TOP VIEWS SHOW THE ZERK FITTINGS (ONE EACH SIDE) AS SHOWN BELOW.

Structural aspects
only approved by
FAA DER SW-222
All Barnhouse
Date 7-16-63....

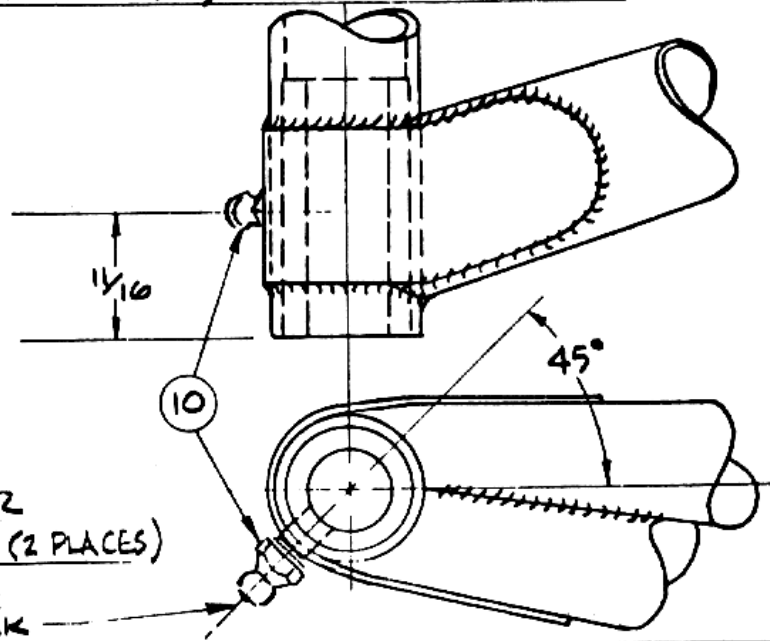

DRILL #3 HOLE AFTER
INSTL OF BEARING (2 PLACES)
TAP 1/4 x 28 UNF-3B
AND INSTALL ZERK